



MFC International offer a range of 0.5 bar pressure high lifting bags designed primarily for the recovery of larger, heavier vehicles and trailers.

These bags have a large contact area which means they uniformly distribute lift pressure across a large surface area, making them suitable for lifting at weak points of a vehicle.

FEATURES

- Provide a strong and steady lift to stabilize a vehicle and improve access to casualties
- Exceptionally stable
- Strong and durable
- Slip-resistant top surface
- Webbing loops assist with lifting and positioning the bags, and can be used as anchorage points
- Low maintenance costs
- Large lift capacity and height
- Controlled deflation capability

USED FOR

- Up-righting heavy or delicate vehicles
- Uprighting structurally weak containers such as fuel tankers or thin composite-walled cargo trailers
- Road traffic accidents
- Lifting aircraft



SUPPLIED WITH

- Repair Kit (with glue: 600005, without glue for US shipping: 600021)

	120	210
Product Code	LB0077	LB0078
Materials	Neoprene Coated Nylon	
Diameter (cm/in)	Ø135 / Ø53	Ø145 / Ø57
Inflated Height (cm/in)	120 / 47	210 / 83
Deflated Height (cm/in)	10 / 4	10 / 4
Max. Pressure (bar/psi)	0.5 / 7.2	0.5 / 7.2
Lift at Max. Pressure (kg/lb)	7,200 / 15,800	9,000 / 19,800
Air Requirements (ltr/ft³)	2,500 / 88	5,200 / 184
Weight (kg/lb)	38.5 / 85	48.5 / 107

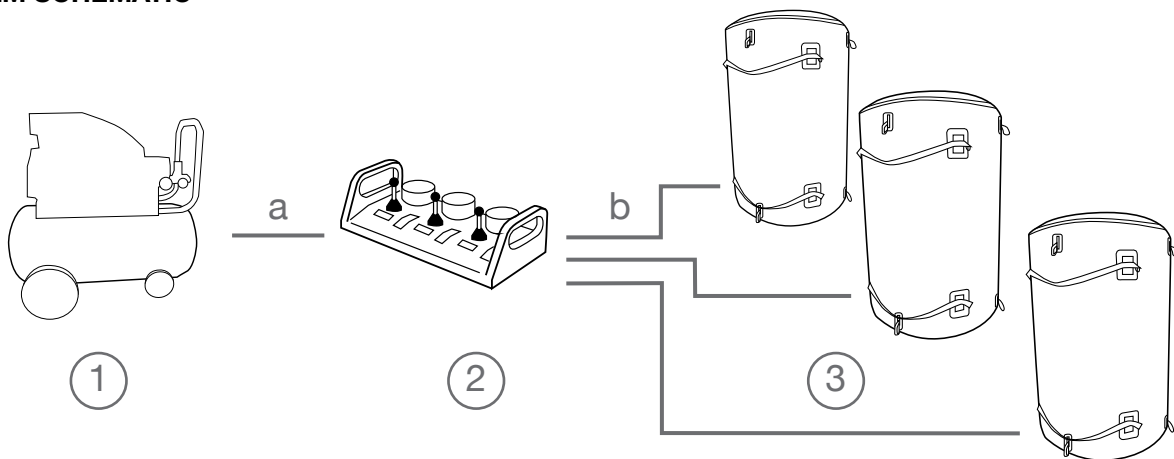
SYSTEM SCHEMATIC

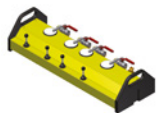

①	②				③
					
Compressor (by others)	Twin Plastic Controller - 1 bar (CO0031)	Aluminium Double Control Unit - 1 bar (CO0130)	Aluminium Triple Control Unit - 1 bar (CO0051)	Aluminium Quad Control Unit - 1 bar <i>Special Order</i>	0.5 bar Low Pressure High-Lift Bags (see table above)
a	b				Option:
					
Yellow Inlet Hose [T26M - T.26M] (2m: HS-01-04-02-06-06 5m: HS-01-04-05-06-06 10m: HS-01-04-10-06-06)	Green Outlet Hose [GEKA] (5m: HS-02-02-05-13-13 10m: HS-02-02-10-13-13)	Red Outlet Hose [GEKA] (5m: HS-02-01-05-13-13 10m: HS-02-01-10-13-13)	Blue Outlet Hose [GEKA] (5m: HS-02-03-05-13-13 10m: HS-02-03-10-13-13)	Shut-off Hose [GEKA] (LB9034)	